

# INSOMNIA

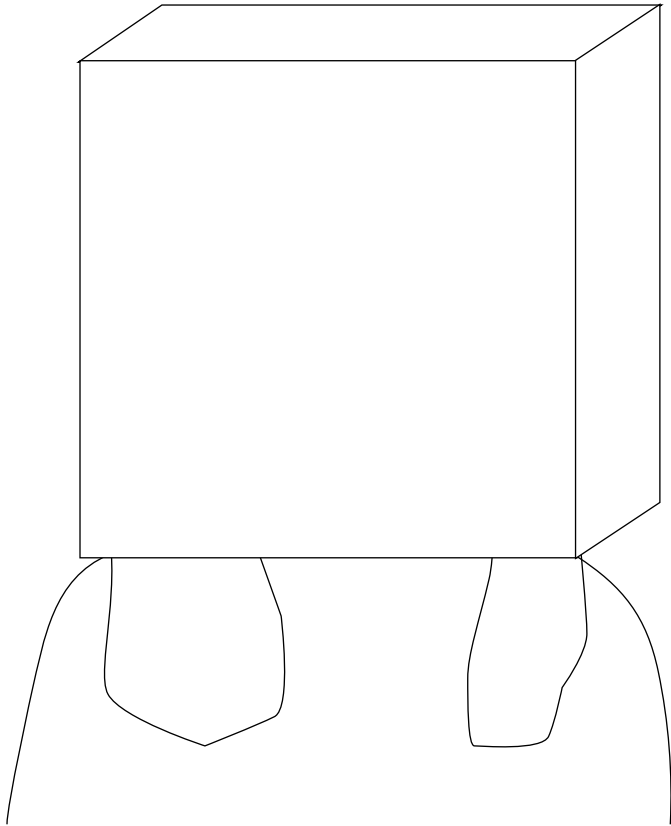

Gadgets to Eliminate  
Tech Health Problems

# TRANQUILITY CUBE

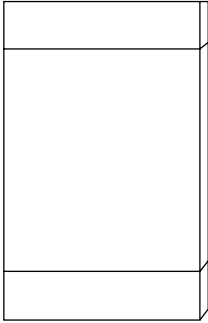

cardboard

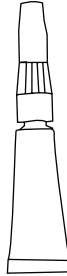

superglue

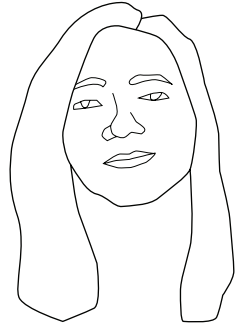

head



ruler

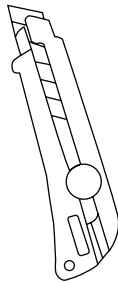

x-acto knife

**1**

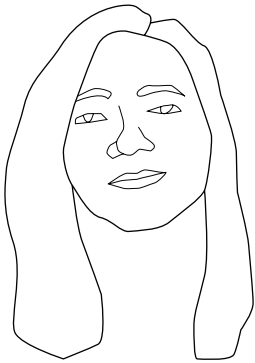

= 30cm

**2**



= 30cm

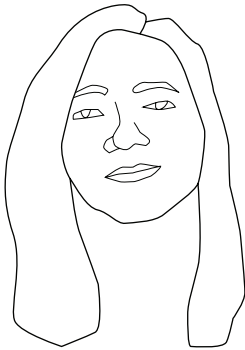

**3**

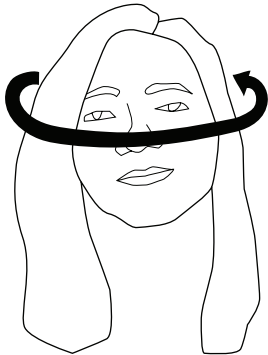

= 55cm

**4**

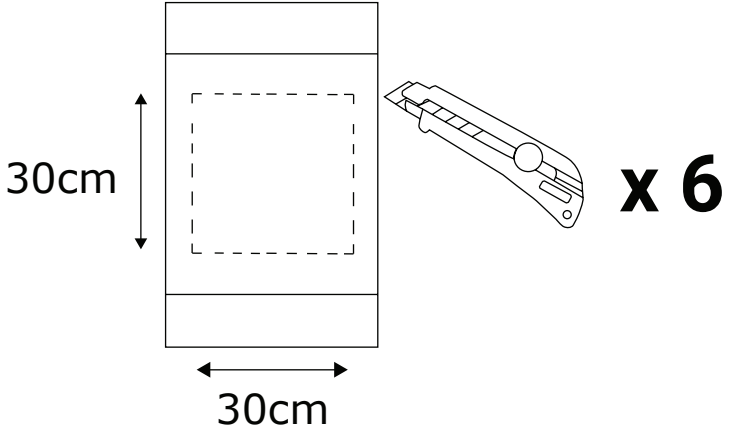

5

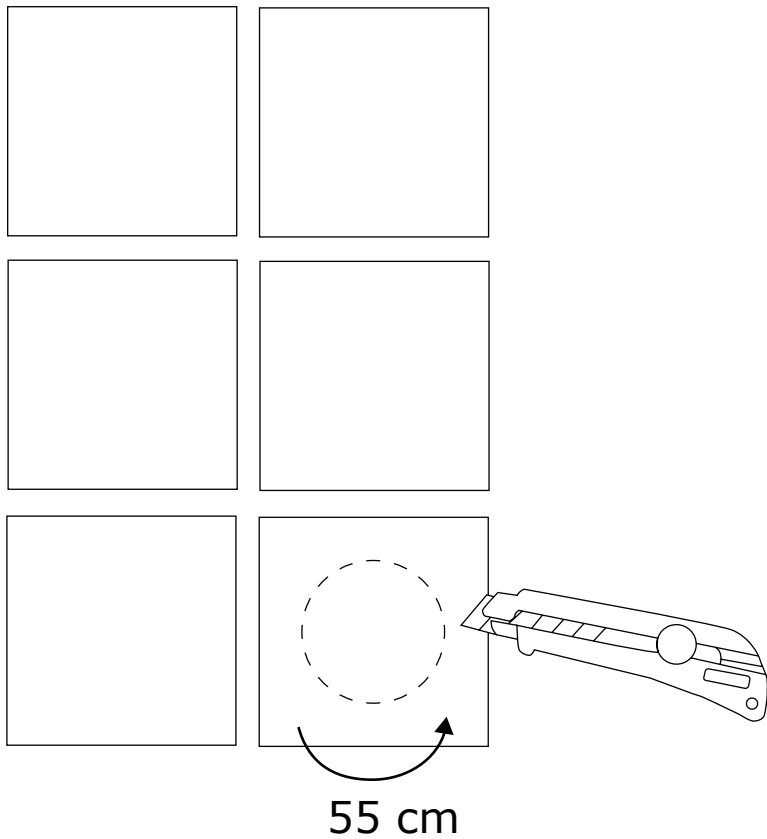

6

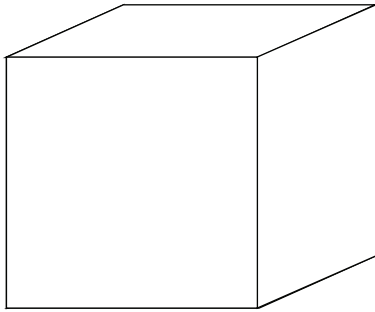
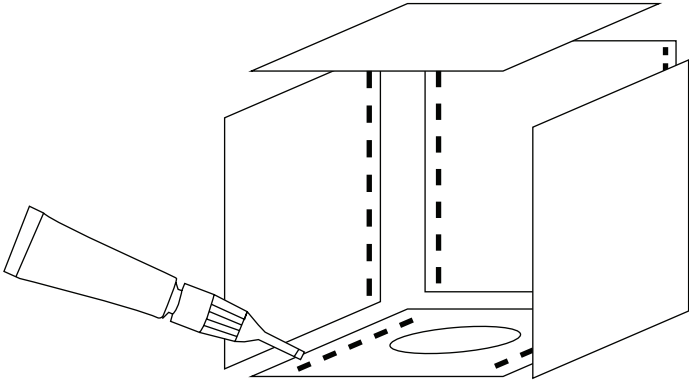

# TRANQUILITY CUBE

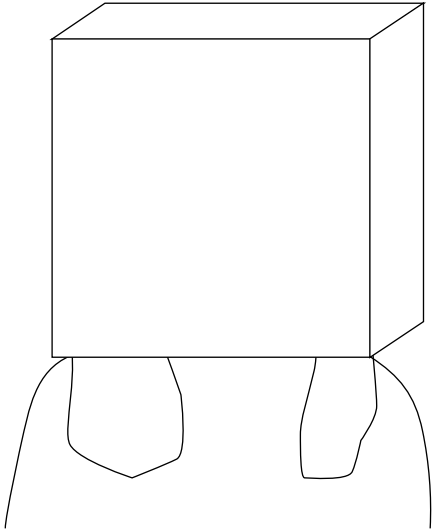
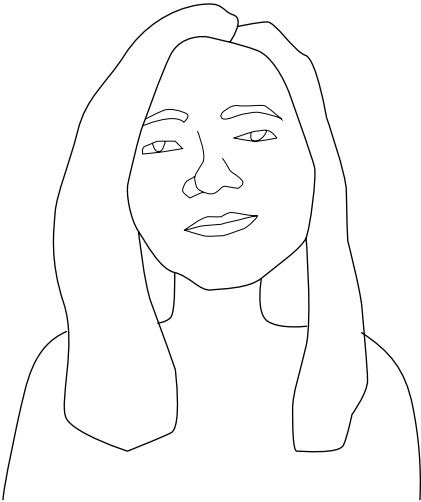
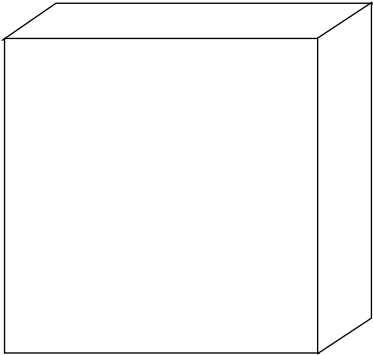

## **About CTP:**

Center For Technological Pain is a non-profit organization focused on offering DIY and Open Source solutions to health problems caused by technology. These solutions range from physical objects that help eliminate certain problems to self-defense moves and classes that help beat tech-addiction.

### **For more information visit:**

*website:*

centerfortechpain.com

*instagram:*

centerfortechpain

*twitter:*

centertechpain